



JOHNSON

JPS-5100H

**GENERATOR STEPPER
ASSEMBLY INSTRUCTIONS**

To avoid possible damage to this Generator stepper, please follow these assembly instructions. Carefully remove all its parts from the box.

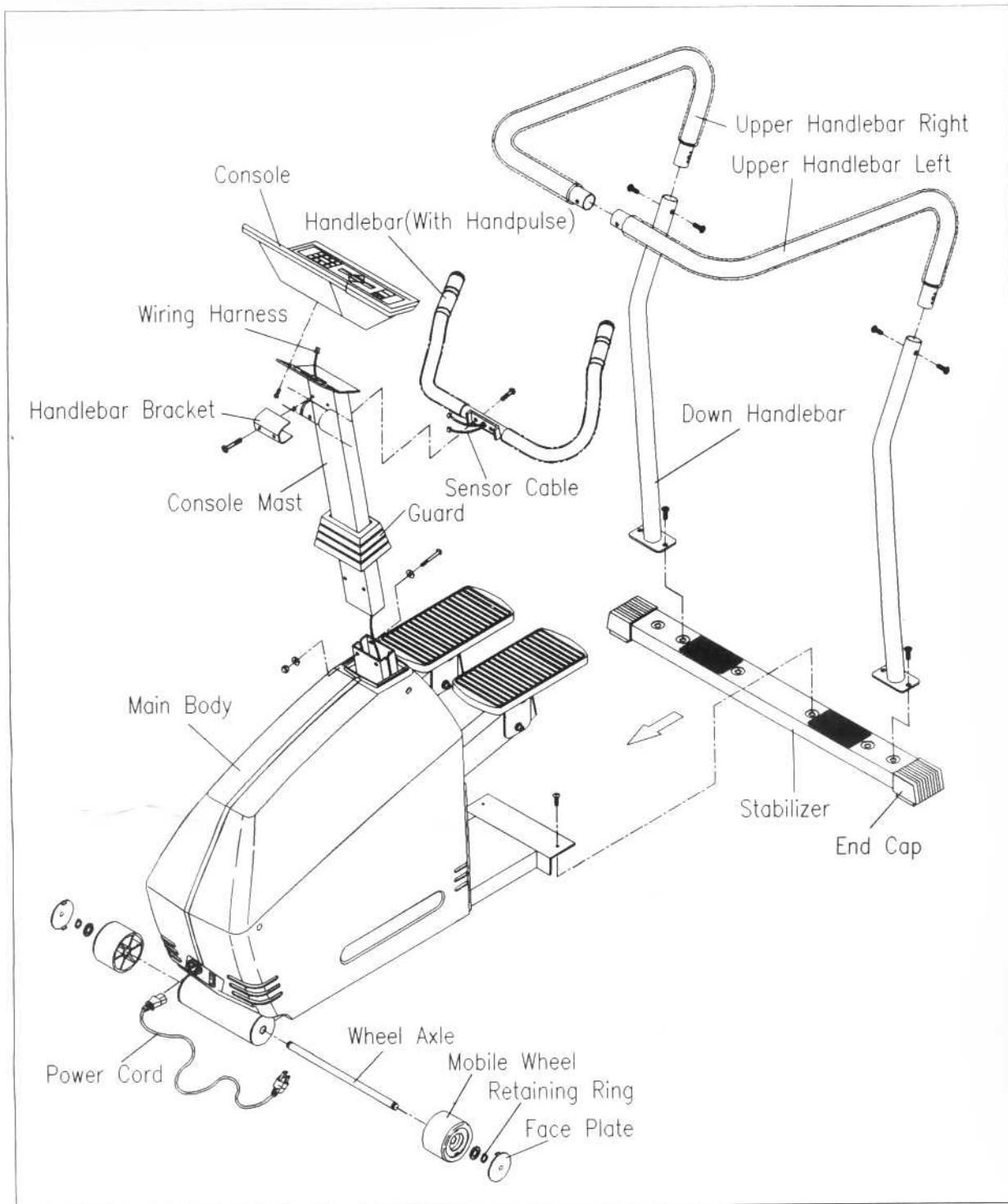

STEPPER ASSEMBLY PARTS









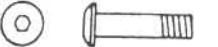

MAIN BODY
END CAP(x2)
STABILIZER
CONSOLE MAST
GUARD
UPPER HANDRAIL (R)
UPPER HANDRAIL (L)
DOWN HANDRAIL (x2)
SENSOR CABLE

CONSOLE
WIRING HARNESS
ADAPTER-ELECTRICAL
MOBILE WHEEL (x2)
FACE PLATE (x2)
WHEEL AXLE
RETAINING RING
HANDLEBAR (WITH HANDPULSE)
POWER CORD

FASTENERS AND ASSEMBLY TOOLS

BUTTON HEAD BOLT (M8x1.25Px55L)	2
BUTTON HEAD BOLT (M8x1.25Px60L)	2
BUTTON HEAD BOLT (M8x1.25Px40L)	2
BUTTON HEAD BOLT (M8x1.25Px16L)	10
BUTTON HEAD BOLT (M5x12)	4
WASHER (Φ 8.2)	4
WASHER (Φ 16.2)	2
RETAINING RING (S-16)	2
NYLON NUT (M8x1.25P)	2
RETAINING RING TOOL	1
ALLEN WRENCH (5mm)	1
SPANNER	1

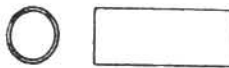
FASTENERS AND ASSEMBLY TOOLS

	BUTTON HEAD BOLT (M8x1.25Px55L)	2
	BUTTON HEAD BOLT (M8x1.25Px60L)	2
	BUTTON HEAD BOLT (M8x1.25Px40L)	2
	BUTTON HEAD BOLT (M8x1.25Px16L)	10
	BUTTON HEAD BOLT (M5x12)	4
	WASHER (Φ 8.2)	4
	WASHER (Φ 16.2)	2
	RETAINING RING (S-16)	2
	NYLON NUT (M8x1.25P)	2
	RETAINING RING TOOL	1
	ALLEN WRENCH (5mm)	1
	SPANNER	1

ASSEMBLY INSTRUCTIONS

Place all parts in a cleared area and remove the packing materials. Do not dispose of the packing materials until the stepper is fully assembled, and all parts are accounted for.

1. REAR TUBE ASSEMBLY (See figure 1)

1. Place rear stabilizer bar under main frame body & align screw holes.
2. Insert and tighten the two M8x16mm screws with a 5mm Allen wrench.

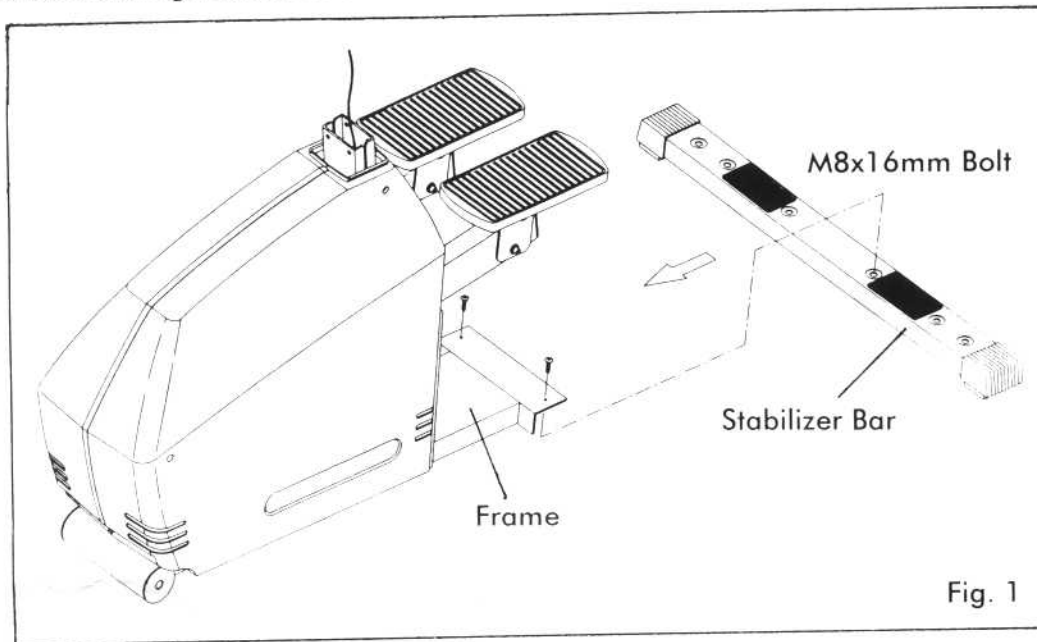

2. MOBILE WHEEL ASSEMBLY (See figure 2)

1. Insert the wheel axle through front base and put on the mobile wheel and washer in order. Then, install the retaining ring on the two ends of wheel axle with retaining ring tool.
 2. Make sure the retaining rings are installed well on wheel axle, then put the face plate on mobile wheel.
- Note: Assure the retaining rings are installed well on axle, then you can put face plate on mobile wheel, because the face plate can not be taken off after it be installed.

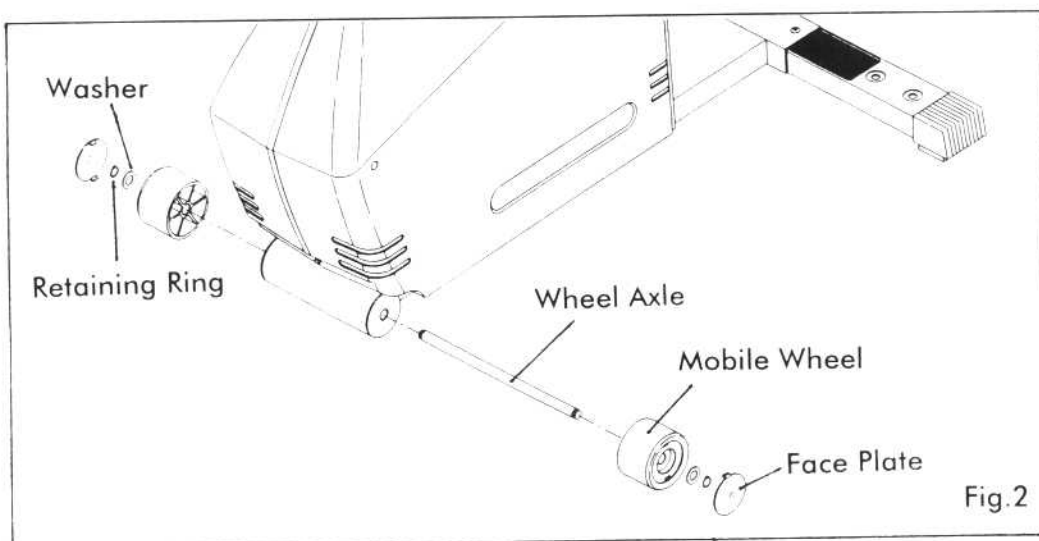

3. CONSOLE POST ASSEMBLY (See figure 3)

1. Install guard onto console mast.
2. Insert the wiring harness into the bottom of the console mast and pull through the top (pull until just tight. **DO NOT PULL HARD!!**) WIRING HARNESS INSTALLATION HINT: Straighten the loops of the wiring harness so that it can be slid smoothly into the console mast. Hold the bottom of the console mast next to the console mast receptor and point the top of console mast downward. Make sure that the handrail bolts are backed out completely so they do not interfere with wiring harness.
3. Install the console mast by sliding it onto console mast receptor. Insert and tighten the two M8x16mm bolts and four dia. 8.2 washers with a 5 mm Allen wrench.
4. Snap Guard into top of Side Case.

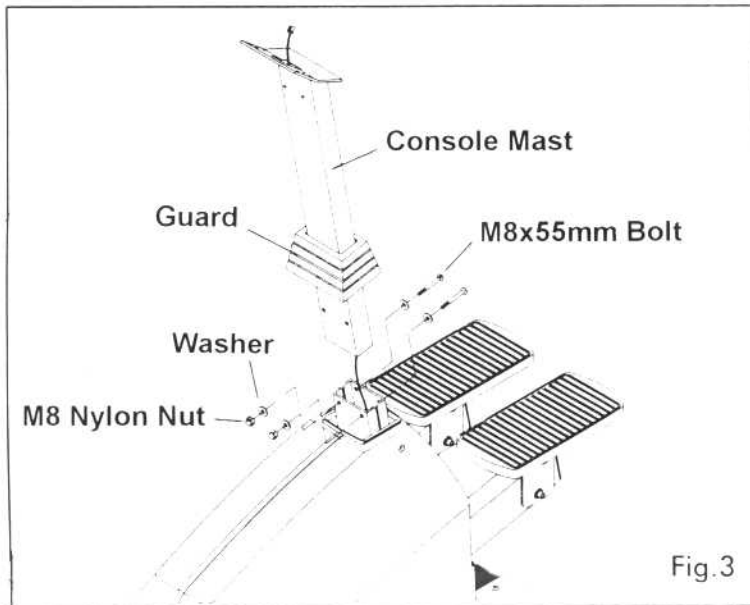

4. HANDRAIL ASSEMBLY (See figure 4)

1. Assemble the upper and lower sections of the right and left handrails using two M8x16mm screws each with a 5mm Allen wrench.
2. Place the left and right handrail assembly into position: assemble the handrail fixed bracket and handrails onto the upper portion of the console mast. Insert and fingertighten the two M8x55mm Allen screws. Align screw holes on bottom of handrails and top of stabilizer bar. Insert and tighten M8x16mm screws into each handrail and tighten with a 5mm Allen wrench. Tighten clamp cover screws on upper portion of console mast with a 5mm Allen wrench.

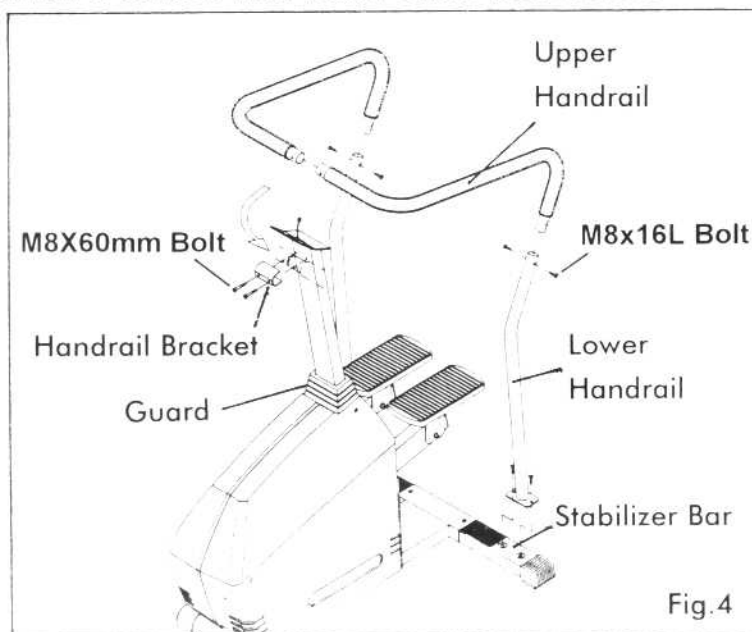

5. HANDLEBAR (WITH HANDPULSE) ASSEMBLY (See fig. 5)

1. Attach the Handlebar on the Console Mast and pull out two sensor cables out from the console mast.
2. Secure the Handlebar with two M8 x 40L screws.

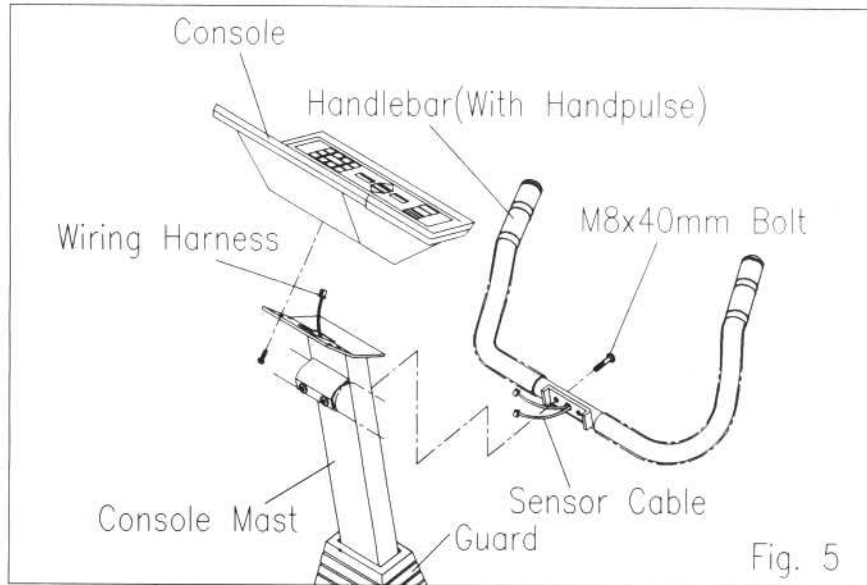

6. CONSOLE ASSEMBLY (See figure 6)

1. Connect the plug from the console to the plug receptor on the backside of the console taking care to install correctly. **WIRING HARNESS INSTALLATION HINT:** Any excess wiring must be carefully inserted ("stored") back into the console mast before installing the console onto the console mast.
2. Fasten the console to the console mast the four M5x12mm screws and washers using a screwdriver.

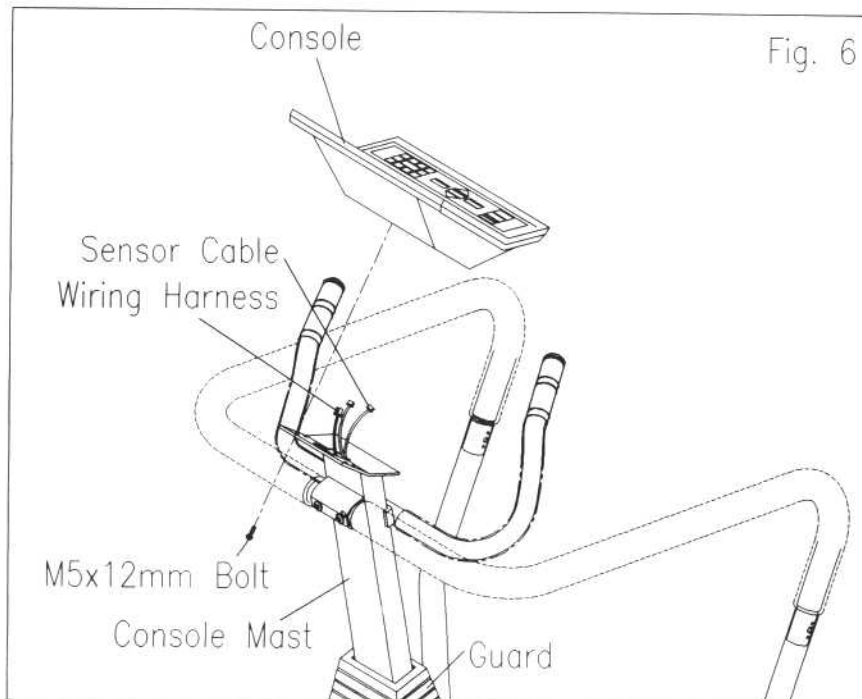

JPS-5100 PARTS LIST

No.	Description	Q'ty	No.	Description	Q'ty
AE1	Pedal Arm-L	1	P06	Transformer	1
AE2	pedal Arm-R	1	P09	Adapter	1
AG3	Sensor	2	P13	Sensor Wire	1
AU1	Middle Tension Wheel Assy	1	P14	Sensor Connecting Wire	2
C08	Bottle	1	P15	Pulse Sensor	1
C09	Bottle Rack Mounting	1	P18	Console Wire	1
C11	Screw M5x0.8Px15L	2	P19	Power Cable	1
D01	Spring Conector, Chain	4	Q01	Left Shroud (+Decal)	1
D02	Chain Connector Sleeve	2	Q02	Right Shroud (+Decal)	1
D03	Pedal Arm Spring	2	Q04	Guard	1
D05	Pedal Arm Spring Connect	4	R01	Axle	1
D06	Pedal Arm Spring	2	R05	Fixed Bearing Housing	1
E02	Pin Pedal Arm	4	R06	Slide Bearing Housing	1
E05	Bumper orusider	2	R08	Middle Axle	1
E13	Positioning Wheel	2	R09	Drive Belt 430-J6	1
E15	Rubber Stop	2	R10	Chain Connector	4
E16	Pedal Arm End Cap 40x80	2	R11	Drive Belt 430-J8	1
E18	Ball Bearing HK1616	8	R12	Chain	1
E27	Ball Bearing HK2516	8	R17	Bearing 6005ZZ	2
F02	Axle Sub-Arm Pedal	1	R27	One Way Bearing HFL3530	2
J02	Foot Pad 40x80	2	R29	Bearing 6002ZZ	2
L01	94 Mobile Wheel	2	R30	Nut AN05 M25x1.5P	2
L02	Mobile Wheel Axle	1	S01	Generator	1
L03	Mobile Wheel Sleeve	2	T01	Pedal	2
L04	94 Mobile Cover	2	T05	Foot	2
L05	C Clip	2	U05	Bearing 6004ZZ	2
N01	Console	1	U09	Bearing 6204ZZ	2
N01	Console W/Hand Pulse	1	V08	Decal	2
P03	Inter Receiver	1	V09	Decal of Motor Cover	1
P05	Control Board	1			

