

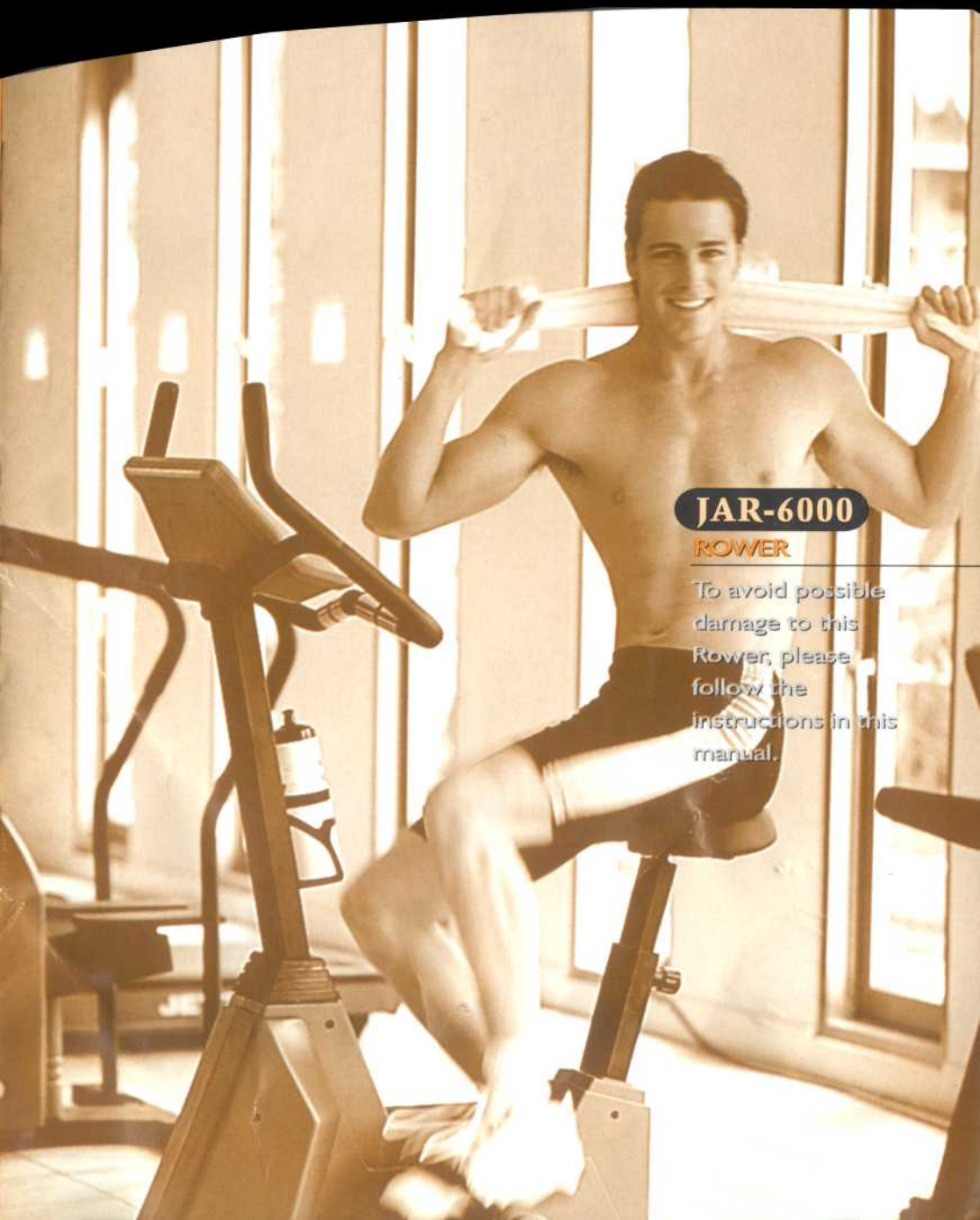

OWNER'S MANUAL



JAR-6000

ROWER

To avoid possible damage to this Rower, please follow the instructions in this manual.

CONGRATULATIONS!

Thank you for making the Johnson Rower a part of your exercise and fitness program. For years to come, you'll be able to rely on Johnson's craftsmanship and durability as you pursue your personal fitness goals.

The Johnson Rower should enable you to shape and monitor your workouts to:

- ▲ Increase your energy level
- ▲ Increase cardiovascular and aerobic capacity
- ▲ Increase lower body muscle strength
- ▼ Decrease your overall percentage of body fat



Whether you are just getting started in an exercise program or are already in good shape, the Johnson Rower is designed to be an efficient, easy and fun way to achieve an enhanced level of fitness. You can step your way to a slimmer and healthier body.

This Owner's Manual contains all the information you need to operate and enjoy your Johnson Rower. Please read this Owner's manual in its entirety before getting onto the Johnson Rower and working out. So let's get started. Take your time and have fun!

TABLE OF CONTENTS

● General Guidelines

Assembly Instructions.....	4 - 6
Turning Screen Display On.....	7 - 8
Important Safety Precautions.....	9

GENERAL GUIDELINES

UNPACKING

Unpack your rower on a level flat surface where you will be using it. Verify that the following parts are included:

● Parts

- | | |
|-------------------------------|------------------------|
| a. 1 Main Frame | b. 1 Aluminum Rail |
| c. 1 Pedal Assembly | d. 1 Seat |
| e. 1 Seat Bracket | f. 1 Console |
| g. 1 Front Foot | h. 1 Rear Foot |
| i. 1 Rear Foot Position Plate | j. 1 Seat Rail End Cap |
| k. 2 Seat Stop Bumper | l. 2 Seat Rail Rod |
| m. 1 Handlebar Bracket | n. 1 Hardware Pack |

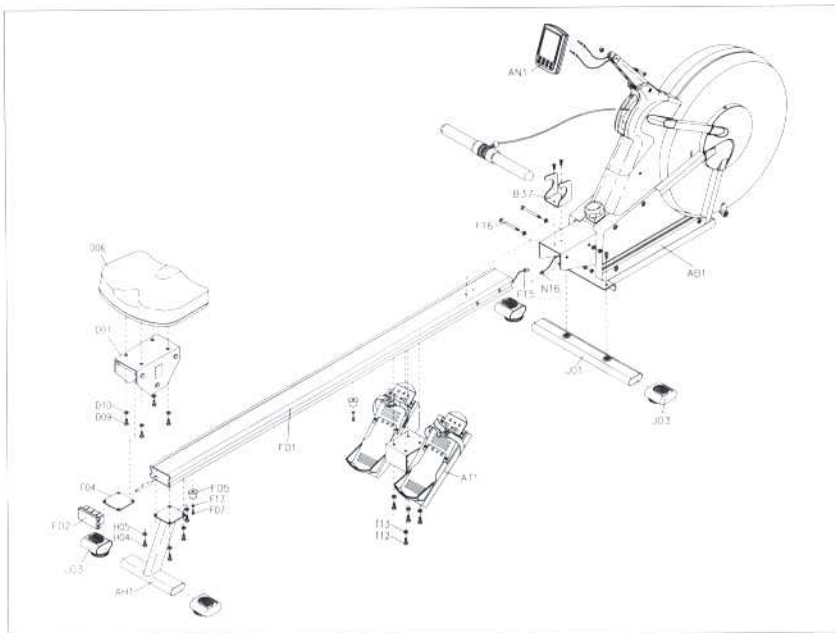

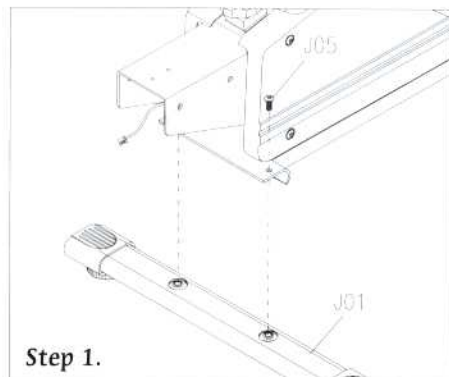
ASSEMBLY INSTRUCTION**Step 1.**

Secure the Front Foot (J01) to the frame bracket using two 15mm long screws (J05).

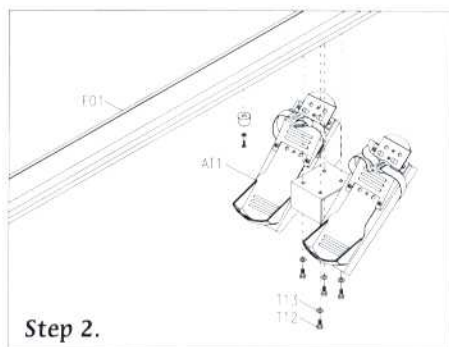
**Step 2.**

Attach the Pedal Assembly (A11) to the Seat Rail (F01) with four 19mm long screws (T12) and spring washers (T13).

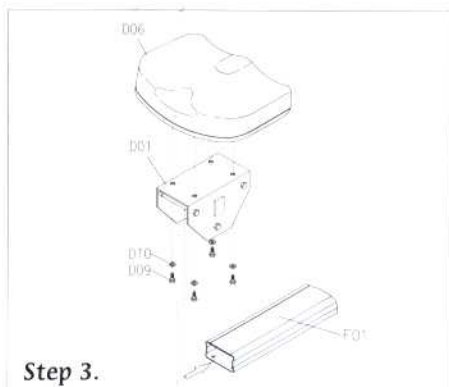
**Step 3.**

Mount the Seat (D06) to the Seat Bracket (D01) with 4 screws (D09) and washers (D10).

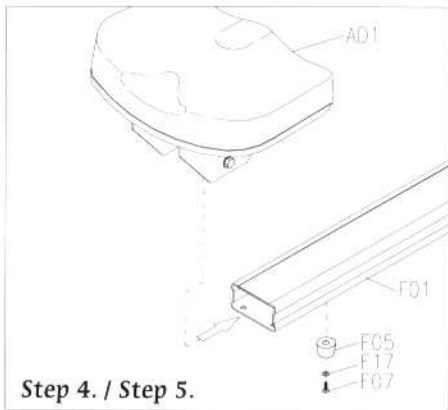

Step 4.

Slide the Seat Assembly (AD1) onto the Seat Rail (F01).

Step 5.

Attach the Seat Stop Bumper (F05) to the Seat Rail (F01) using two 15mm long screws (F07) and washers (F17).

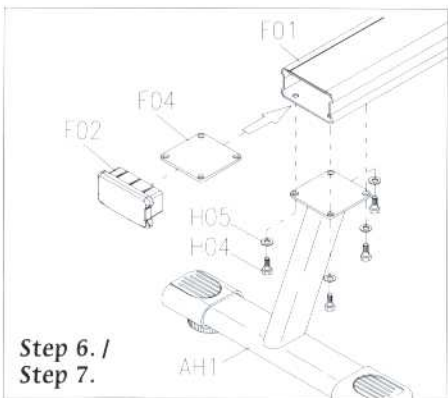

Step 6.

Place the Rear Foot Position Plate (F04) in the Seat Rail (F01) close to the edge. Attach the Rear Foot (AH1) to the Seat Rail (F01) and align the four holes in the Seat Rail (F01) with the four holes in the frame lip. Thread the 19mm long bolts (H04) with spring washers (H05) through the frame lip into the Rear Foot Position Plate (F04) and tighten them.

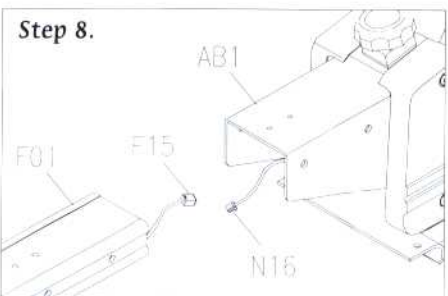

Step 7.

Press the Seat Rail End Cap (F02) into the Seat Rail (F01).

Step 8.

Connect Sensor Cable (F15) and (N16).

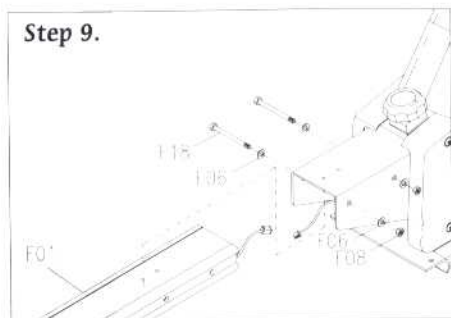

Step 9.

Place the Seat Rail (F01) into the rail bracket on Main Frame (AB1). Slide the Seat Rail Rod (F18) with the washers (F06) through the holes in the rail bracket and tighten them using nylon nuts (F08) and washers (F06).

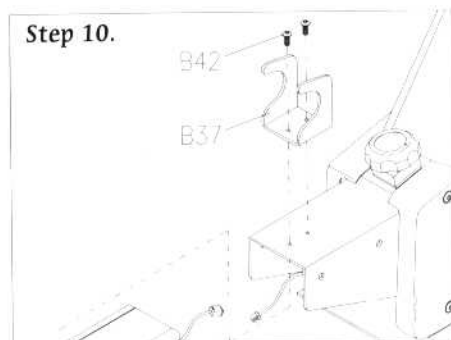

Step 10.

Mount the Handlebar Bracket (B37) to rail bracket using two 15mm long bolts (B42).

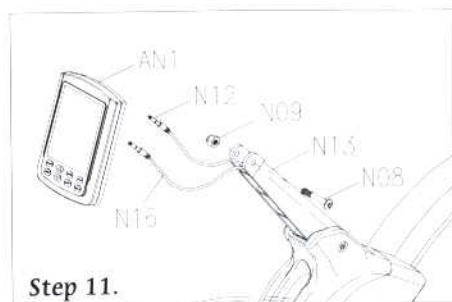

Step 11.

Plug the two Console Cable (N12) into the Console (AN1). Secure the Console (AN1) to the console support (N13) using the 40mm long bolt (N08) and nylon nut (N09).

TURNING SCREEN DISPLAY ON

To turn the screen display on, press POWER button. When the display comes on, "00:00" will be flashing in the TIME window.

● MANUAL MODE

You can either choose Time or Distance as your target.

1. Choose Time and Starting: Use the ▲ ▼ buttons to enter your workout time. Time of between 1 and 180 minutes can be selected. When the time you choose is showing in the TIME window, press START button. The timer will begin counting down to zero. When the workout time is completed, the console will beep 3 times and the screen will flash 3 times.
2. Choose Distance and Starting: Press the SELECT button and "0" will be flashing in the METER window. Use the ▲ ▼ buttons to enter your workout distance. Distance of between 100 and 30000 meters can be selected. When the distance you choose is showing in the METER window, press START button. The console will begin counting down to zero. When the workout distance is completed, the console will beep 3 times and the screen will flash 3 times.

● RACE PROGRAM

With Race Program, you compete with the computer pacer.

1. Press RACE button and "500" will be flashing in the METER window.
2. Use ▲ ▼ buttons to enter your race distance. Distance of between 500 and 30000 meters can be selected. When the distance you choose is showing in the METER window, press SELECT button and "L09" will be flashing in the CAL. window.
3. Use ▲ ▼ buttons to enter your race speed (PACE / 500M). When the level you choose is showing in the window, press START button.

L01 - 08:00 L02 - 07:30 L03 - 07:00 L04 - 06:30
L05 - 06:00 L06 - 05:30 L07 - 05:00 L08 - 04:30
L09 - 04:00 L10 - 03:30 L11 - 03:00 L12 - 02:30
L13 - 02:00 L14 - 01:30 L15 - 01:00

● TRAINING PROGRAM

SPM training. You can either choose Time or Distance as your training target.

Choose Time and Starting:

1. Press TRAINING button and "00:00" will be flashing in the Time window.
2. Use ▲ ▼ buttons to enter your training time. Time of between 1 and 180 minutes can be selected.
3. Press SELECT and "14" will be flashing in SPM window.
4. Use ▲ ▼ buttons to enter your desired SPM. SPM of between 6 and 99 / minute can be selected. When the SPM you choose is showing in the window, press START button.

Choose Distance and Starting:

1. Press TRAINING button to enter Training Mode.
2. Press SELECT button and "0" will be flashing in the METER window.
3. Use ▲ ▼ buttons to enter your training distance. Distance of between 100 and 30000 meters can be selected.
4. Press SELECT and "14" will be flashing in SPM window.
5. Use ▲ ▼ buttons to enter your desired SPM. SPM of between 6 and 99 / minute can be selected. When the SPM you choose is showing in the window, press START button.

IMPORTANT SAFETY PRECAUTIONS

● WARNING

To reduce the risk of serious injury, read the important safety precautions before using this equipment.

1. Read all instructions in this manual before using this equipment.
2. Use this equipment only as described in this Owner's Manual.
3. Position the Rower on a level surface. The electric monitor must be out of direct sunlight or the LCD display may be damaged.
4. Inspect and tighten all parts before using this equipment. Replace any worn parts immediately.
5. Keep hands away from moving parts.
6. Keep small children away from this equipment during use.
7. Wear appropriate workout attire, including running or aerobic shoes, when using the rower.

● WARNING

Before beginning any exercise program, always consult your physician. If you experience chest pains, nausea, dizziness or shortness of breath, stop exercising and consult your physician before continuing.



JOHNSON METAL INDUSTRIES CO., LTD.

NO.26 CHING CHUAN ROAD, TAYA HSIANG, TAICHUNG HSIEN, TAIWAN, R.O.C

TEL : 886-4-25667100 FAX : 886-4-25683456 E-MAIL : sales@johnsonfitness.com

Website : www.johnsonfitness.com